

S.M. Services (UK) Ltd

18 Orchard Way, Cranfield, Beds. MK43 0HU. Tel 01234 751095

ON BOARD GLO CONTROLLER



Specifications

Size.	46mm x 28mm x 20mm
Construction.	Boxed.
Connections.	Via screw block connectors.
RX Supply Voltage.	4.0 to 10v DC.
Supply Current.	5mA off 50mA on approx.
Output.	Isolated contacts rated 5A @ 30v DC. Red led indicates relay is closed.
Timing Pulse.	Positive going 1.5mS nominal.

Description.

This module is designed to improve the problems of poor throttle response and cutting out from slow running conditions. The module is for use with two or four stroke glo engines, single or twin cylinders. The module is driven directly from the receiver via a Y lead. The switching point is adjustable across the full throttle range, signal reversing is also available. A four second delay is incorporated on glo switch of to allow the engine to pick up when rapidly opening the throttle. A separate arming switch is not required as the glo battery is automatically disconnected when the receiver battery is switched off. For normal use a sub C battery is adequate for plug energisation.

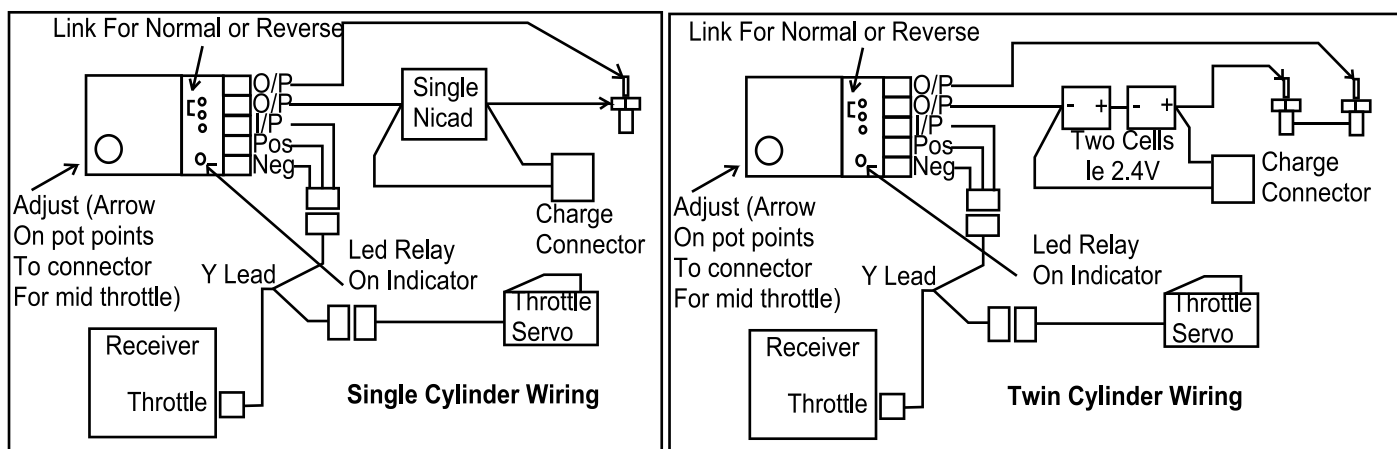

Standard receiver wiring connections.

Lead function	Futaba	JR/New Sanwa	Hitec	Sanwa (old)
Positive = +	Red	Red	Red	3
Negative = -	Black	Brown	Brown	2
Signal	White	Orange	Yellow	1

Please refer to your equipment instructions for wiring codes if they are not listed.

WARNING

1. Do **NOT** reverse positive and negative wires. (Red and Black)
 2. **ALWAYS** remove power from the unit before connecting or disconnecting any input or output connection, Failure to observe this instruction can damage both the unit or the equipment it is connected to.
 3. **ALWAYS** range check when adding to or changing the control system of a model.
 4. S.M. Services (UK) Ltd products are tested for use on the UK 35 Mhz aircraft frequency, use on other frequencies should not be a problem, however use on frequencies other than 35 Mhz is at the users risk.
- If you have any questions or problems with this product please contact us, we are here to help you.

Your Guarantee

S.M. Services (UK) Ltd guarantee all products for 1 year from date of purchase. During this time S.M. Services (UK) Ltd will repair or replace all defective products free of charge, except for Units subject to fair wear and tear, or units that are subject to crash damage. To qualify for benefits under the guarantee you must have installed and used the product in accordance with S.M. Services (UK) Ltd instructions. Consequential losses and accidental damage to the product are not covered by the guarantee. S.M. Services (UK) Ltd cannot be held responsible for results of using our products for any purpose other than those described in the relevant instructions.

Returns

Any returned products ordered in error or are not required will if returned unopened in original product packaging within 28 days from date of purchase be subject to a full refund less shipping charges and a 5% handling charge. All other returns will be subject to a full refund less shipping charges and a 20% handling charge.